

# CASA GRACIO

*QUALITY REPORT*

# INDEX

- INTRODUCTION
- QUALITY REPORT
- DESIGN AND MATERIALS
- CONTACT INFORMATION

AN  
IBICENCAN  
DREAM

# QUALITY REPORT

## *FOUNDATION AND STRUCTURE*

- The foundation will be executed using reinforced concrete (isolated footings, continuous footings, and retaining walls) in accordance with the geotechnical study.
- It will be a stable and durable structural system, designed based on detailed calculations and an in-depth understanding of the terrain, the structure, the installations, and the specific characteristics of the construction.
- The structure will consist of reinforced concrete beams and pillars, combined with concrete walls.
- Solid reinforced concrete slabs and unidirectional slabs will be used for the flooring.

## *FINISHES AND ROOF*

- The façades will be constructed with honeycomb brick and 8 cm of thermal XPS insulation on the interior side, with a fine earth-colored concrete mortar finish on the exterior.
- Roof of pladur in color white
- On the first floor and basement

# DESIGN AND MATERIALS

## *PARTITION WALLS*

- Laminated plasterboard
- With projected rock wool insulation to ensure optimal acoustic insulation.
- False ceilings
- Double boards of pladur

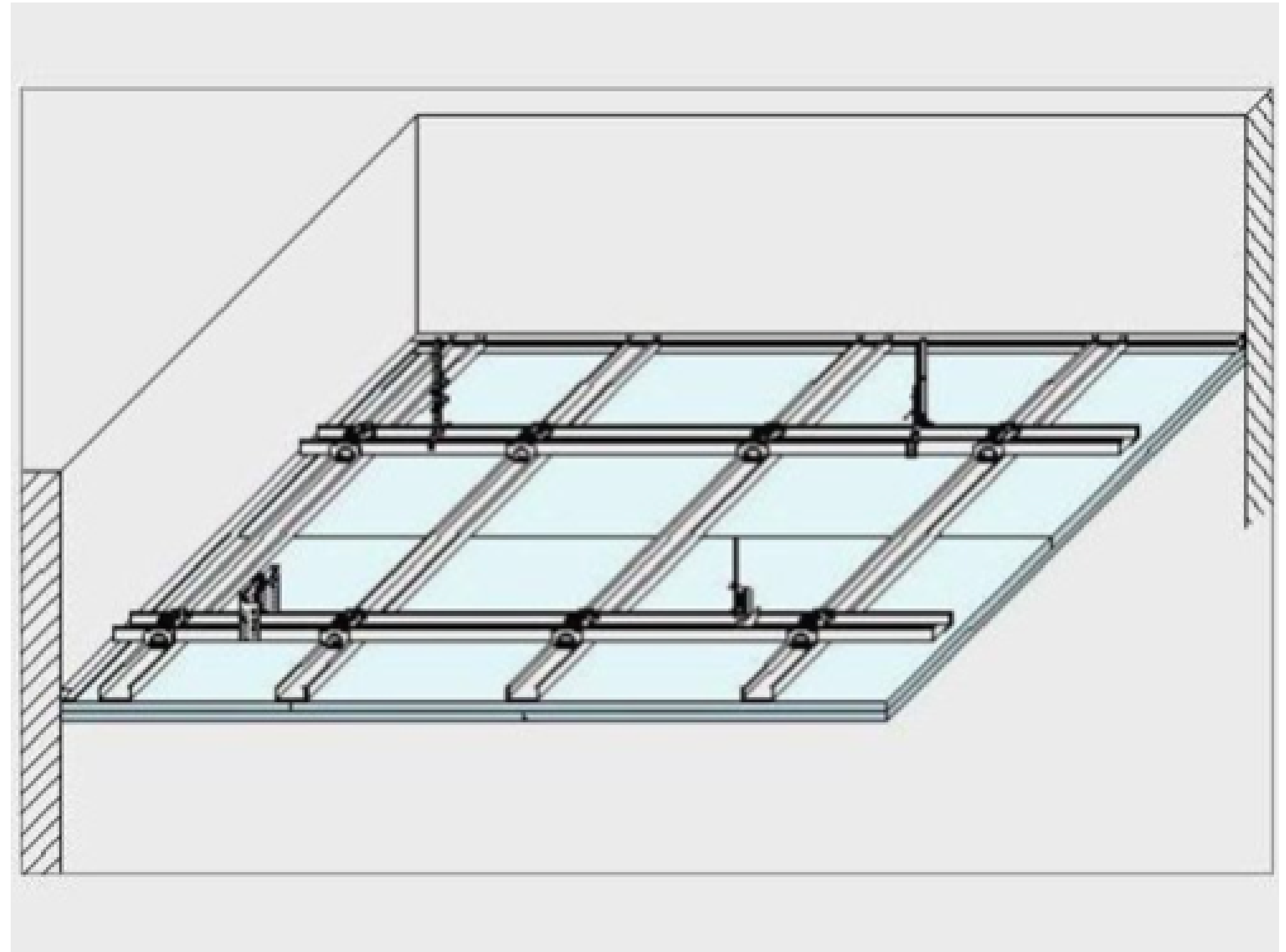

# REPORTE DE CALIDAD

## FAÇADES

- The façade will be finished with earth-colored concrete mortar, honeycomb brick, 8 cm of extruded polystyrene insulation, an air chamber with a self-supporting profile, and double plasterboard panels.

## WALL CONSTRUCTION

- Acoustic thermal brick (11 cm thick) with projected rock wool insulation on the interior face.



# REPORTE DE CALIDAD

## *SANITARYWARE AND FAUCETS*

- Large designer bathtubs in the master bathroom, of high quality, to be chosen by the client.
- showers, sinks, and vanities in special formats, with bases to be selected by the client, of medium-high quality.
- Faucets to be chosen by the client, of medium-high quality.
- Wall-mounted toilets to be selected by the client, of medium-high quality.

## *POOL*

- System of filtration
- 200x300 dimensions

## *BASEMENTS*

- Same quality of floor
- Dressed walls
- Electrical pre-installation
- Bathroom pre-installation
- Thermal insulation

## *TELECOMMUNICATIONS*

- Collective satellite and terrestrial radio and television broadcasting and television installations

# DESIGN AND MATERIALS

## *WALL FINISHES*

- Shower walls
- White porcelain or similar to the picture
- Waterproof sheeting



# DESIGN AND MATERIALS

CASA  
GRACIO

## *EXTERIOR FLOORING*

- Light earth cement mortar



# DESIGN AND MATERIALS

## *INTERIOR FLOORING*

Including wet areas and basements:

- Vinyl floor YNOVA

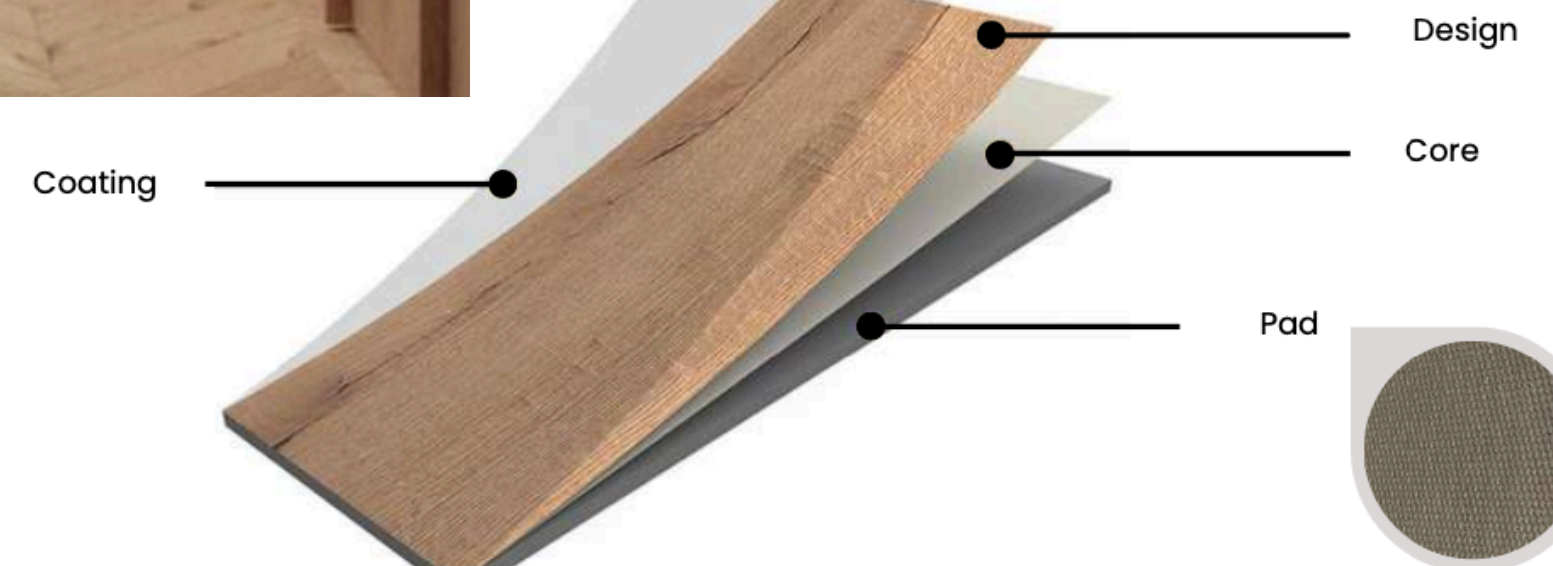

# DESIGN AND MATERIALS

CASA  
GRACIO

## *EXTERIOR FLOORING*

### CERAMIC

1. Concrete finish
2. Marble finish



# DESIGN AND MATERIALS

CASA  
GRACIO

## *CARPENTRY*

Exterior carpentry:

- Windows and sliding doors of aluminium in color black



# DESIGN AND MATERIALS

## *CARPENTRY*

Main entrance door:

- Security door
- White lacquered block door .



# DESIGN AND MATERIALS

## *CARPENTRY*

Interior carpentry:

- Block door wood color



# DESIGN AND MATERIALS

CASA  
GRACIO

## CARPENTRY

Custom-made wardrobes & walk-in closets in wood color



# DESIGN AND MATERIALS

CASA  
GRACIO

## *KITCHEN*

- Kitchen of a Spanish brand
- Wood and black matte



## *ROOTS KITCHEN*

- Extra options



## *OPTIONAL EXTERIOR KITCHEN*

- Optional custom-made exterior kitchen

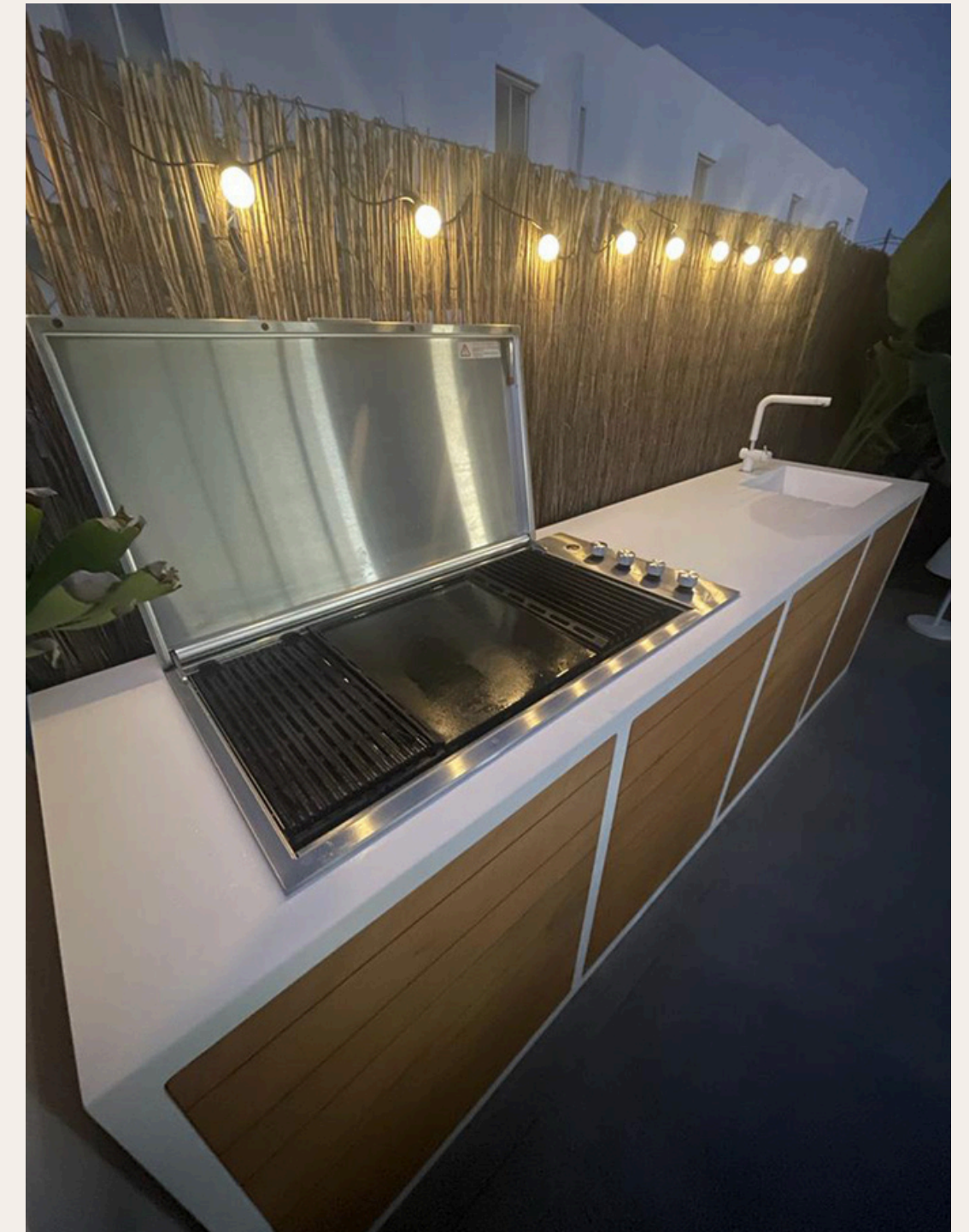

# DESIGN AND MATERIALS

CASA  
GRACIO

## *KITCHEN*

- Appliances
- Ceramic hob
- Integrated extractor fan
- Refrigerator
- Dishwasher



# DESIGN AND MATERIALS

CASA  
GRACIO

## *SANITARYWARE AND FAUCETS*

- Wall hung basin



- Ochre-colored faucets

# DESIGN AND MATERIALS

## SANITARYWARE AND FAUCETS

- Compact concealed cistern by Geberit

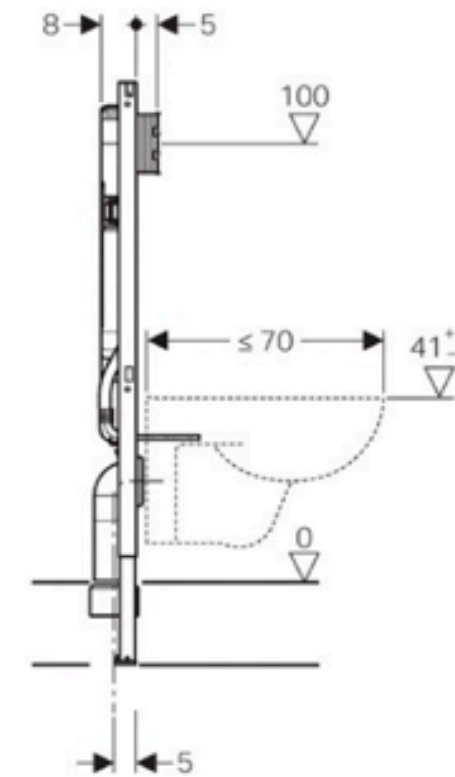
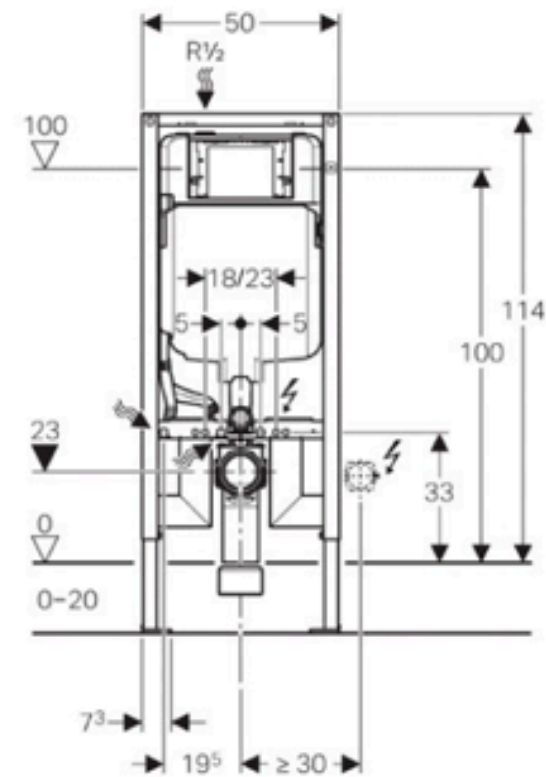

- Wall-mounted toilet Geberit Icon



- Geberit Sigma 70 flush plate in white glass





# GUARANTEE

CASA  
GRACIO

- 2 years of guarantee
- References, promotor : <https://www.candalt.es/>

# CONTACT



## **Ibiza Estates**

info@ibiza-estates.com

www.ibiza-estates.com

## **Office Ibiza**

+34 871 183 071

Carrer des Cap Martinet 19

07819 Jesus, Ibiza

Spain

## **Office The Netherlands**

+31 40 851 3993

Aalsterweg 262

5644 RK Eindhoven

The Netherlands

[WWW.IBIZA-ESTATES.COM](http://WWW.IBIZA-ESTATES.COM)